

Direct Observation of Bimodal Amphiphilic Surface Structures of Zeolite Particles for a Novel Liquid–Liquid Phase Boundary Catalysis

Shigeru Ikeda,[†] Hadi Nur,[†] Tetsuro Sawadaishi,[‡] Kuniharu Ijro,[‡]
Masatsugu Shimomura,[‡] and Bunsho Ohtani^{*†}

Catalysis Research Center, Hokkaido University, Sapporo 060-0811, Japan, and Research Institute for Electronic Science, Hokkaido University, Sapporo 060-0812, Japan

Received July 16, 2001. In Final Form: October 18, 2001

Amphiphilic NaY zeolite particles were prepared by a partial modification of the external surface of NaY with alkylsilyl groups. When the particles were added to a mixture of aqueous hydrogen peroxide and normal alkene, they were feasibly located just at the liquid–liquid phase boundary and efficiently catalyzed epoxidation of the alkenes even without stirring. Fluorescence microscopic observation of these particles selectively modified with fluorescent dye revealed that each particle has a bimodal amphiphilic surface structure; one side of the external surface is hydrophilic and the other is hydrophobic.

In view of the current interest in establishment of environmentally benign and ecologically more acceptable chemical processes, there is an increasing emphasis on utilization of solid catalyst particles instead of the use of either stoichiometric reagents or homogeneous catalysts. Several solid catalysts, such as zeolites, supported oxides, and clays, have been extensively studied for the development of environmentally benign chemical processes by using their acid and base or oxidation catalytic properties.^{1–3} However, one of the major problems encountered in the use of solid catalysts is the difficulty of effective interaction between water-immiscible substrate(s) and catalyst particles owing to their hydrophilicity, which hinders the contact with hydrophobic compounds in the organic phase. Two strategies have been proposed so far to overcome this problem. One is the addition of cosolvents to eliminate the phase boundary between organic and water phases and to give a homogeneous solution, and the other is stirring of the reaction mixture vigorously to make an emulsion.^{4–6} These systems may increase the effective concentration of reactants on the catalyst surface and thus give successful results. At the same time, however, the enhanced contact of organic and water phases with the catalyst may induce the production of undesired byproducts and/or decomposition of product(s). Moreover, complicated workup procedures, such as separation of products from the solvent including unreacted reagents, are necessary.

Recently, we have found a novel method for partially modifying the external surface of zeolite particles with alkylsilyl groups.⁷ The particles could be placed at a liquid–liquid phase boundary between aqueous hydrogen peroxide and water-immiscible organic compounds and act as an efficient catalyst for epoxidation of 1-octene

without stirring. The reaction system is thus named “phase-boundary catalysis (PBC)”. In our previous paper, we briefly reported some of the phenomenological aspects of catalytic functions in PBC. However, the structures of catalyst particles governing their catalytic property had not been clarified. In the present study, therefore, we examined PBC and the structure of amphiphilic catalyst particles in more detail, focusing on clarification of the distribution of alkylsilyl groups on the external surface of particles by using fluorescence microscopy.

Experimental Section

Sodium zeolite Y (NaY) supplied by the Catalysis Society of Japan (JRC-Z–Y5.5) was used as model zeolite particles. Titanium oxide species, active sites for epoxidation, were loaded by impregnation as follows. Titanium(IV) tetra-2-propoxide (0.142 g, 500 μ mol, Wako Pure Chemical) dissolved in 20 cm³ of benzene (dried with molecular sieve 4A) was added to 1.0 g of NaY powder, and the suspension was stirred at room temperature in open air until the benzene was almost evaporated. Then the resulting powder was heated at 383 K overnight. Here, the as-prepared zeolite loaded with titanium oxide is called Ti–NaY. An amphiphilic zeolite whose external surface was partially covered with alkylsilyl groups was prepared as follows. To 1 g of Ti–NaY, 0.5 cm³ of water was added and the mixture was stirred by a spatula until the added water soaked into Ti–NaY particles uniformly. The thus-obtained NaY aggregates were suspended in 10 cm³ of toluene solution containing 500 μ mol of octadecyltrichlorosilane (OTS, Tokyo Kasei Organic Chemical). After the mixture was shaken for ca. 5 min at room temperature, the suspension was centrifuged to remove unreacted OTS and washed with CCl₄ (50 cm³) and ethanol (50 cm³), and the precipitates were dried at 383 K overnight. The thus-prepared particles were labeled w/o–Ti–NaY.

A similar procedure was also carried out to prepare fully modified Ti–NaY (o–Ti–NaY) without addition of water in the above procedure for preparation of w/o–Ti–NaY particles. In a typical experiment, OTS (500 μ mol) was dissolved in a mixed solution (10 cm³) of toluene (80 vol %) and CCl₄ (20 vol %). A dried sample of Ti–NaY (1 g) was added to the solution, and the mixture was stirred overnight at room temperature. A solid sample was collected by centrifugation, washed with CCl₄ (50 cm³) and ethanol (50 cm³), and dried at 383 K overnight.

Epoxidation of normal alkene with hydrogen peroxide was performed as follows. The modified NaY particles (50 mg), normal alkenes (4 cm³), and 30% of aqueous H₂O₂ (1 cm³) were placed in a glass tube and reacted for 20 h at room temperature. In some experiments, the mixtures were stirred magnetically. 1-Hexene

* To whom correspondence should be addressed.

[†] Catalysis Research Center.

[‡] Research Institute for Electronic Science.

(1) Corma, A. *Chem. Rev.* **1997**, *97*, 2373–2419.

(2) Izumi, Y. *Catal. Today* **1997**, *33*, 371–409.

(3) Dusi, M.; Mallat, T.; Baiker, A. *Catal. Rev.* **2000**, *42*, 213–278.

(4) Bhaumik, A.; Kumar, R. *J. Chem. Soc., Chem. Commun.* **1995**, 349–350.

(5) Tatsumi, T.; Koyano, K. A.; Igarashi, N. *Chem. Commun.* **1998**, 325–326.

(6) Bhaumik, A.; Mukherjee, P.; Kumar, R. *J. Catal.* **1998**, *178*, 101–107.

(7) Nur, H.; Ikeda, S.; Ohtani, B. *Chem. Commun.* **2000**, 2235–2236.

Scheme 1. Schematic Representation of the Procedure for Site-Selective Loading of Fluorescent Dye on Modified NaY Particles

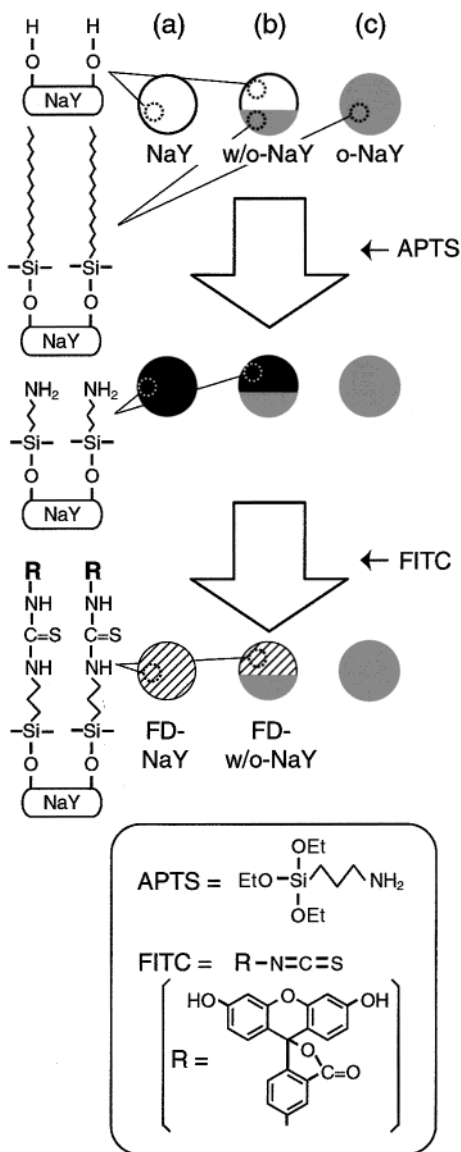

and 1-dodecene (Kanto Chemical) were used without further purification. Due to the appreciable amount of impurities, 1-octene (Kanto Chemical) was purified with basic alumina (Merck) before use. Reaction products were analyzed by gas chromatography (Shimadzu GC-14B, PEG 1000 or Tenax TA column, FID detector, N_2 carrier).

For clarification of the surface structures of these particles by fluorescence microscopy, fluorescein isothiocyanate (FITC) was attached to the surfaces of these particles by the procedure shown in Scheme 1. First, to 1 g of NaY (unmodified, denoted as NaY, w/o-NaY, or o-NaY) without Ti loading, 500 μmol of aminopropyltriethoxysilane (APTS, Shinetsu Chemical) dissolved in toluene (10 cm^3) was added. After the suspension was stirred for 1 h at room temperature, the particles were collected by centrifugation, washed with CCl_4 (50 cm^3) and ethanol (50 cm^3), and dried at 383 K overnight. To these APTS-modified NaY particles (200 mg), ca. 0.1 mmol of FITC hydrochloride (Research Organics) in methanol (10 cm^3) was added and stirred at room temperature overnight. After separation of the particles by centrifugation, they were washed several times with 10 cm^3 of methanol and dried at room temperature in the dark for 24 h. Removal of unreacted FITC from the particles was confirmed by its negligible absorption in the supernatant by UV-vis spectrometry (Hewlett-Packard HP8453).

Fluorescence microscopic observation was performed at room temperature using a fluorescence microscope (Olympus BHT-

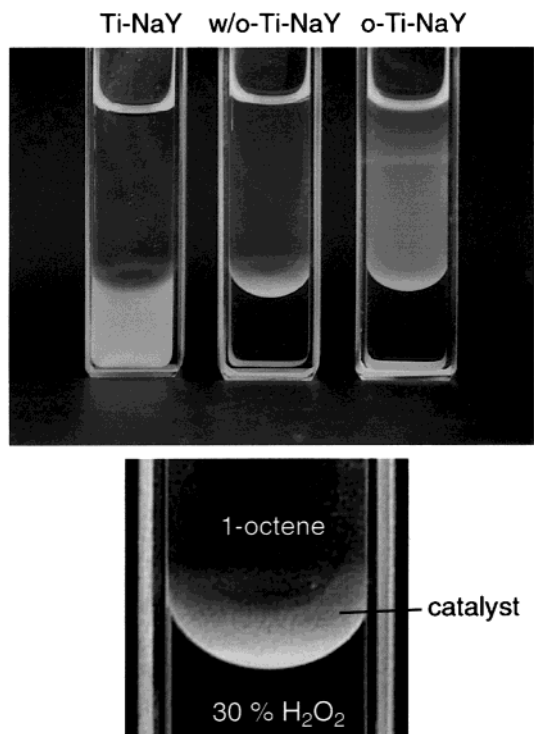

Figure 1. Photographs of modified NaY zeolite particles in a 1-octene-aqueous hydrogen peroxide (30%) mixture: (a) Ti-NaY, (b) w/o-Ti-NaY, (c) o-Ti-NaY.

RFK) and a CCD camera (BITRAN BS-30L) with a "B filter" for excitation at 480 nm. The FITC-modified particles were dispersed in ethanol by ultrasonication for a few minutes. The upper part of the suspension was spread on a glass plate and used as a sample. We could observe the particles being ca. 10–40 μm in size, aggregates of crystallites (ca. 1 μm), with sufficient resolution to compare the difference between the samples.

Results and Discussion

Figure 1 shows the apparent locations of Ti-NaY, w/o-Ti-NaY, and o-Ti-NaY suspended in a 1-octene–30% aqueous hydrogen peroxide (H_2O_2) mixture. Since an NaY particle itself and loaded titanium oxide species are originally hydrophilic owing to their surface hydroxyl groups, the Ti-NaY particles were only dispersed in the aqueous H_2O_2 phase (Figure 1a). When the surface hydroxyl groups of Ti-NaY were modified with OTS, as has been extensively used for silica,^{9,10} these particles (o-Ti-NaY) became hydrophobic due to the surface coverage of alkylsilyl groups. As expected, o-Ti-NaY was only dispersed in 1-octene (Figure 1c). Similar behavior has been reported by Dutta et al.⁸ To adjust the surface coverage of alkylsilyl groups, a small amount of water, slightly more than the water-absorption capacity of Ti-NaY estimated by a separate experiment,¹¹ was added to the dried Ti-NaY powder before the reaction with OTS. Since the capillary force of water induces tight adhesion

(8) Singh, R.; Dutta, P. K. *Microporous Mesoporous Mater.* **1999**, *32*, 29–35.

(9) Banga, R.; Yarwood, J.; Morgan, A. M.; Evans, B.; Kells, J. *Langmuir* **1995**, *11*, 4393–4399.

(10) Solberzan, P.; Leger, L.; Ausserré, D.; Benattar, J. J. *Langmuir* **1991**, *7*, 1647–1651.

(11) Water absorption capacity of Ti-NaY was measured at room temperature by a simple absorption technique. A 1 g portion of NaY dried at 573 K was exposed to air with high humidity (90–100%) at ambient pressure. After the exposure, the weight increase of the particles was recorded in several intervals and the saturated increase (ca. 30%) was assumed to be the absorption capacity.

Table 1. Room Temperature Epoxidation of Normal Alkenes on Several Modified Ti-NaY with 30% Aqueous Hydrogen Peroxide^a

alkene	epoxide yield/ μmol^b					
	Ti-NaY		w/o-TiNaY		o-NaY	
	stirring	static	stirring	static	stirring	static
1-hexene	4.5	0	16.2	51.6	4.5	7.2
1-octene	2.5	0.2	27.4	27.0	5.9	3.6
1-dodecene	0	0	20.0	17.7	3.2	0

^a All reactions were carried out for 20 h with normal alkenes (4 mL), 30% H_2O_2 (1 mL), and catalyst (50 mg). The concentration of Ti was 500 mmol g^{-1} . ^b Yields of corresponding 1,2-epoxide of alkenes.

between the particles, leading to aggregation,^{12,13} and since the binding water prevents insertion of a hydrophobic OTS molecule into the aggregates, OTS can only react with hydroxyl groups existing on the outer parts of aggregates.¹⁴ Therefore, the surface of w/o-Ti-NaY is expected to be bimodal, having both hydroxyl and alkylsilyl faces. Upon dispersion of w/o-Ti-NaY in the 1-octene–30% aqueous H_2O_2 mixture, the particles were assembled at the liquid–liquid phase boundary (Figure 1b). Similar behavior was also observed when w/o-Ti-NaY was added to several mixtures of aqueous (water)/organic (oil) solution. The characteristic behavior of w/o-Ti-NaY particles is attributed to their appropriate balance of hydrophilicity and hydrophobicity. We have confirmed the reproducibility of preparation of the amphiphilic particles.

Table 1 summarizes the results of epoxidation of normal alkene by Ti-NaY, o-Ti-NaY, and w/o-Ti-NaY. Corresponding epoxides were obtained as major products in all cases. Ti-NaY showed lower activity than did the others, and the epoxide yield under a static condition was much lower than that under the condition of vigorous stirring. Notably, the reaction did not occur even under the condition of stirring when 1-dodecene was used as a substrate. Similar behavior was seen in the o-Ti-NaY system except for 1-hexene epoxidation in which the yield of 1,2-epoxyhexane under a static condition was higher than that under the condition of vigorous stirring. The activity of w/o-Ti-NaY was much higher than those of Ti-NaY and o-Ti-NaY. It is notable that the activity of w/o-Ti-NaY was independent of the stirring rate; i.e., this catalyst does not require the formation of an emulsion by stirring at ca. 1000 rpm. When 1-hexene was used as a substrate, the yield of 1,2-epoxyhexane under a static condition was three times higher than that obtained under the condition of stirring. A semiquantitative analysis by gas chromatography–mass spectrometry (GC–MS) revealed appreciable liberation of byproducts such as ketone (hexenal) and alcohol (hexenol) under the condition of stirring. Therefore, the higher yield of 1,2-epoxyhexane under the static condition was partly attributable to the suppression of further oxidation and/or side reaction. Details of the catalytic function toward several alkenes are to be presented elsewhere.¹⁵

(12) Fuji, M.; Machida, K.; Takei, T.; Watanabe, T.; Chikazawa, M. *Langmuir* **1999**, *15*, 4584–4589.

(13) Fuji, M.; Machida, K.; Takei, T.; Watanabe, T.; Chikazawa, M. *J. Phys. Chem. B* **1998**, *102*, 8782–8787.

(14) The external surfaces of aggregates were not wetted apparently though the amount of added water was larger than the estimated water-absorption capacity of Ti-NaY. When more than 1 cm^3 of water was added in a 1 g portion of dried Ti-NaY particles, aggregates becomes gluey and, as expected, the resulting alkylsilylated particles seemed heterogeneous; some particles were located in the liquid–liquid phase boundary and others were dispersed in water.

(15) Nur, H.; Ikeda, S.; Ohtani, B. *J. Catal.*, in press.

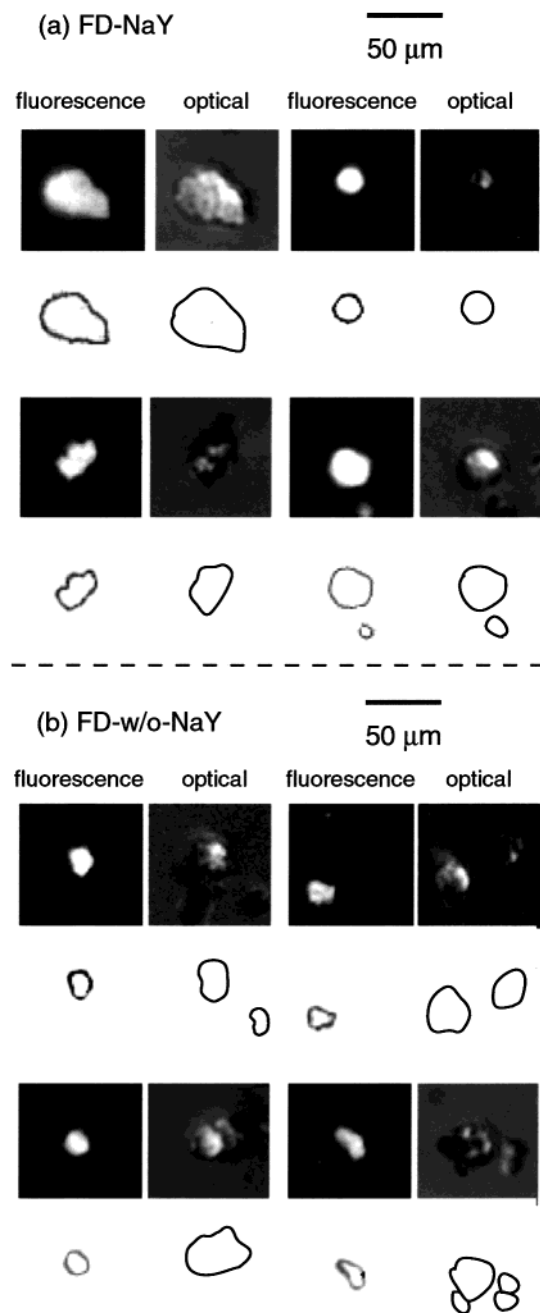

Figure 2. Fluorescence and optical micrographs of fluorescent dye-modified NaY particles: (a) FD-NaY, (b) FD-w/o-NaY. Outlines are shown for comparison.

On the basis of the above results, the characteristic behavior of w/o-Ti-NaY particles, e.g., their feasible location at the liquid–liquid phase boundary and the remarkable catalytic ability of the particles for epoxidation of normal alkenes, are attributed to the amphiphilic feature of each particle, i.e., each w/o-Ti-NaY particle has both hydrophilic and hydrophobic faces. To prove this, we tried to determine the distribution of hydroxyl groups on w/o-Ti-NaY particles by fluorescence microscopy. The procedure to make the original nonfluorescent NaY surface fluorescent consisted of two steps: aminoalkylation of hydroxyl groups on the bare surface and then attachment of fluorescent dye molecules through the amide linkage. As a result, the whole external surface of unmodified NaY and a (hydrophilic) part of the w/o-NaY surface without attached alkylsilyl groups might be covered with the dye molecules (Scheme 1a,b). On the other hand, due to the

full surface coverage with hydrophobic alkylsilyl groups on o-NaY, APTS cannot react with its surface to retain inertness of the surface to FITC. Thus, the fluorescent dye molecules were expected to be attached only on the hydrophobic surface, i.e., the external surface of NaY was expected to be fully covered with the dye molecules (FD-NaY) and that of w/o-NaY partly covered with them (FD-w/o-NaY); o-NaY could not be fluorescent (Scheme 1c). UV-visible diffuse reflectance spectroscopy revealed that FD-NaY has strong absorption and FD-w/o-NaY has less-intense absorption at about 400–550 nm, while o-NaY treated with APTS and FITC gives no absorption in this region (data not shown). These facts agree with the above-mentioned expectation, and we could therefore exclude the possibility of existence of physically adsorbed fluorescent dye species.

Figure 2 shows representative fluorescence and optical microscopic images of FD-NaY and FD-w/o-NaY. For FD-NaY particles, there was no appreciable difference in shape (as shown by outlines in Figure 2) between fluorescence and optical images; i.e., aminopropylsilyl groups and fluorescent dye molecules were grafted on the whole external surface (Figure 2a), as expected. On the other hand, in the case of FD-w/o-NaY, only a part of the particles was fluorescent (Figure 2b). These findings confirmed that hydroxyl groups on w/o-NaY were exposed on only one side of the external surface and the remainder of the external surface was covered with alkylsilyl groups, hindering the reaction with APTS and FITC; i.e., each particle of w/o-NaY has both a hydrophilic and a hydrophobic surface. It should be noted that some of the w/o-NaY particles gave either fluorescence on the whole surface or negligible fluorescence. It is thus reasonable to assume that partially alkylsilylated particles with different orientations existed on a sample glass plate.

Thus, we have clarified the amphiphilic surface structure of the modified NaY particles used in PBC systems, one side being hydrophilic and the other hydrophobic. It is reasonable to assume that during the reaction in PBC, the w/o-NaY particles are spontaneously located at the liquid-liquid phase boundary in an aqueous-organic

mixture, facing the hydrophobic alkylsilylated surface to the organic phase and the hydrophilic side to the aqueous phase. In this situation, both normal alkenes and H₂O₂ in the aqueous phase can be continuously supplied through the hydrophobic and hydrophilic surfaces of w/o-Ti-NaY. As shown in Figure 1c, some of the o-Ti-NaY particles seem to be situated at the liquid-liquid phase boundary due to gravity. Actually, all of them became assembled at the phase boundary after standing for a few hours. Similar behavior was also observed for H-ZSM5 modified by several silane coupling reagents suspended in an aqueous (water)/organic (oil) mixture.^{16,17} However, because of the lack of hydrophilic sites (surfaces) for supplying H₂O₂, o-Ti-NaY showed much lower activity than that of w/o-Ti-NaY. This is consistent with the PBC mechanism mentioned above.

Although we could only observe relatively larger (ca. > 10 μm) particles in the present study due to the limitation of resolution of fluorescence microscopy, we believe that the basic concept of amphiphilic catalyst particles driving the reaction at the liquid-liquid phase boundary has been proved. The apparent rate of epoxidation was lower than that previously reported.⁵ Therefore, to design a more efficient catalyst particle in PBC, structural analyses in the nanometer-to-micrometer region, e.g., more detailed analyses of the surface structure of amphiphilic particles, local structure, and distribution of loaded titanium species, are now underway.

Acknowledgment. The authors are grateful to the Catalysis Society of Japan for supplying zeolite samples. This research was partly supported by a Grant-in-Aid for Encouragement of Young Scientists (No. 13750753) from the Japan Society for the Promotion of Science (JSPS). H.N. thanks the JSPS for financial support.

LA011088C

(16) Ogawa, H.; Tensai, K.; Taya, K.; Chihara, T. *J. Chem. Soc., Chem. Commun.* **1990**, 1246–1247.

(17) Ogawa, H.; Xiuhua, H.; Chihara, T. *Catal. Lett.* **1998**, *55*, 121–123.